



Cast Iron Oil-Fired Steam Boiler

INTRODUCING

CSFE STEAM

KEEPING FAMILIES  *WARM SINCE 1936*



Quality Engineered for Efficiency and Dependability

Increased Efficiency & Reliability for Homes Heated with Oil

The CSFE oil-fired steam boiler now offers improved efficiency and reliability with a re-designed heat exchanger and protective heat shield, as well as an electronic low water cut-off.



New Patent Pending Design

With efficiencies up to 85% AFUE, the ENERGY STAR rated CSFE optimizes your fuel dollars through a newly re-designed heat exchanger and patent pending protective heat shield baffle.



The modified pin deck and baffle design enhance the heat transfer process and protect the casting from poor water conditions for added longevity.

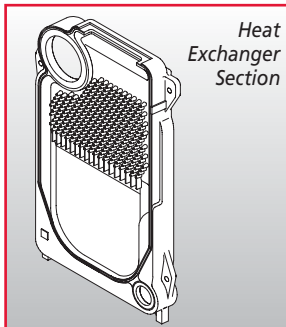

Electronic Low Water Cut-Off

An electronic low water cut-off replaces the former mechanical design. The electronic low water cut-off does not require flushing which reduces make-up water. The electronic low water cut-off also maintains tighter control of water level variation.



Cast-Iron Sections and Push Nipples

The CSFE utilizes durable and efficient cast-iron sections and push nipples. The highest quality cast-iron and latest heat transfer design allows the CSFE to provide many years of efficient, trouble-free operation.

Easy Access & Maintenance

A sturdy cast-iron swing door allows for quick and easy inspection of the oil burner and combustion area while extra large flue ways allow for easy cleaning and set-up. The flue way openings are easily accessed through an integrated two-part draft hood. All components are easy to reach, greatly reducing the time spent on regular maintenance and service calls.



High- Performance Burner Versatility

The CSFE accommodates various oil burners with choices of manufacturer approved burners from Beckett, Carlin or Riello.

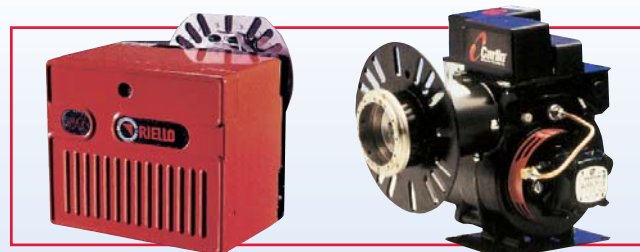

Quiet Operation

The CSFE's recessed target wall and swing door mounting plate enlarges the combustion area contributing to its quiet operation.



Integral Skim Tapping

An integral skim tapping simplifies the mechanics of this basic service function. Periodic skimming contributes to trouble-free operation, and the CSFE provides a pre-threaded outlet to make this procedure even easier.



Tankless Water Heater Option

An optional tankless hot water coil is offered with the CSFE. It features off-set tappings to speed installation and service. When used with a flow control and tempering valve, the tankless heater is an ideal method of providing domestic hot water for most installations.

Factory Pre-Wired & Tested

Each CSFE boiler is shipped with controls pre-wired and is subjected to a series of rigorous quality assurance tests to provide quick and easy setup in the field.



CSFE Boiler Details

- Cast-Iron Heat Exchanger
- Quality Burner Options
- Steam Pressure Control
- Cast-Iron Swing Door
- Optional Tankless Water Heater
- Electronic Low Water Cut-Off
- Water Sight Glass
- Pressure Gauge
- Service Switch



Optional Tankless Water Heater

Produces hot water for domestic use. See table on back page for "Tankless Water Heater Capacities." Inspection and service are made easier with the coil's raised port which is accessible without removing the jacket.



Beckett Burner Features

- Interrupted Duty Ignition
- PSC Motor
- Clean Cut Solenoid Valve

CSFE Features

- Increased efficiencies up to 85% AFUE
- Re-designed Heat Exchanger with:
 - Patent Pending Protective Heat Shield Baffle
 - Swing Door
 - Cast Iron Sections and Push Nipples
- Recessed Target Wall
- Special Burner Mounting Plate – increases Combustion Chamber
- Large Flue Way Opening
- Tankless Heater Option
- Electronic Low Water Cut-Off
- Wide range of sizes to fit residential and light commercial applications

CSFE, SFH-E & ST Series

RATINGS AND DATA

BOILER MODEL NUMBER ¹	I = B = R OIL BURNER INPUT ^{2,5}		D.O.E. HEATING CAPACITY MBH ⁵	STEAM MBH	I = B = R NET RATINGS ^{3,5}		NOZZLE FURNISHED 140 PSIG	A.F.U.E. RATING
	G.P.H.	MBH			SQ. FT. STEAM	PUMP PRESS. PSI		
*CSFE-0365S	0.65	91	79	59	246	140	.60 80°B	85.00
CSFE-3100S	1.00	140	116	87	363	140	.85 80°B	81.50
*CSFHE-4100S	1.00	140	120	91	377	140	.85 80°B	85.00
CSFE-4125S	1.25	175	145	109	454	140	1.10 80°B	82.50
CSFE-4150S	1.50	210	170	128	533	140	1.25 80°B	81.00
CSFE-5175S	1.75	245	202	152	633	140	1.50 80°B H	83.00
CSFE-5200S	2.00	280	227	170	708	140	1.75 70°B H	82.00
CSFE-6225S	2.25	315	251	188	783	140	2.00 45°B	—
CSFE-7275S	2.75	385	307	230	958	140	2.25 45°B	—

* Indicates an ENERGY STAR efficient product.

Nozzles with an H designation are Hago brand, all others are Delevan.

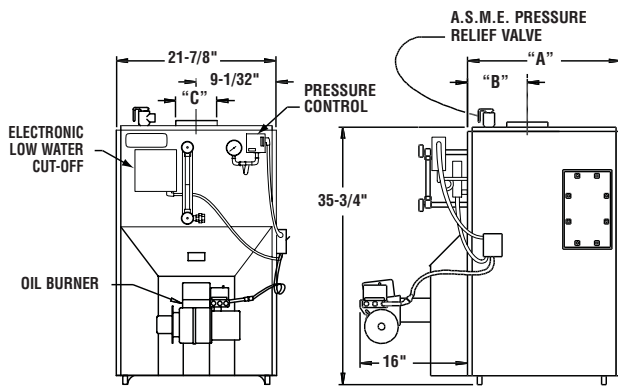

DIMENSIONS

BOILER MODEL NO.	A LENGTH OF FLUSH JACKET	B FRONT OF JACKET TO C/L OF FLUE OUTLET	C DIAMETER OF FLUE OUTLET
CSFE-3S	16%	6½	6
CSFE-4S	20%	8½	6
CSFE-5S	23%	10¼	7
CSFE-6S	27½	8⅝	8
CSFE-7S	31%	8⅝	8

NOTES

- Add suffix "T" to denote boiler with tankless heater.
- I=B=R burner capacity is based on an oil heating value of 140,000 Btu/gal. and with 13% CO₂.
- Net ratings based on heat emission of 240 Btu per square foot per hour and a piping and pick-up allowance of 1.33.
- Nozzle listed is for use with Beckett AFG burner. When alternate burner is used, consult burner manufacturer's recommendations.
- Gallons of water per minute heated from 40° to 140° F with 200° boiler water temperature.

STANDARD EQUIPMENT

Crated Cast Iron Boiler, Flush Jacket, Swing-Out Burner Door, Clean Cut AFG Beckett Oil Burner, Target Wall/Liner, ASME Relief Valve, Steam Water Level Gauge, Steam Pressure Gauge, Steam Pressure Control, Electronic Low-Water Cut-Off, Drain Cock, Wiring Harness, Burner Electric Disconnect, Plastic Cover, Supply Tapping (Qty. 2 - 2"), Return Tapping - 1 1/2" and Primary Control. For Tankless Heater Units Add: Tankless Hot Water Coil, Flow Restrictor and Limit Control. Note: 1/2" Coil Tappings on All Models.

(Specifications and dimensions are subject to change without notice.)

MEA# 182-86E

TANKLESS WATER HEATER CAPACITIES

BOILER MODEL NUMBER	TANKLESS HEATER NUMBER	TANKLESS HEATER CAPACITY INTERMITTENT DRAW G.P.M.	BOILER WATER CONTENT GALS.
CSFE-0365S	L-24	3.0	11
CSFE-3100S	L-24	4.5	11
CSFE-4100S	L-24	4.5	13
CSFE-4125S	L-24	4.5	13
CSFE-4150S	L-24	4.5	13
CSFE-5175S	L-24	5.0	15
CSFE-5200S	L-24	5.0	15
CSFE-6225S	L-24	5.0	17
CSFE-7275S	L-24	5.0	19

YOUR ASSURANCE OF QUALITY

Columbia Boilers products are designed, tested, and assembled to ensure that you get the very best in home heating and cooling comfort, and value. Each one meets or exceeds all recognized safety, performance and efficiency standards.



Tested for 15 Lbs. ASME Working Pressure



LEARN MORE AT energystar.gov



For more information on Columbia Boilers heating products contact your local Columbia Boilers distributor or call Columbia Boilers at (410)242-5300 or (610)323-9200.

Columbia Heating Products
1409 Rome Road, PO Box 24202
Baltimore, MD 21227
Tel 410-242-5300 Fax 410-247-5026
Web Site: www.columbiaheating.com

Columbia Heating Supply
390 Old Reading Pike, PO Box 377
Pottstown, PA 19464
Tel 610-323-9200 Fax 610-323-8532

Form No. CSFE 7/08